



POSEIDON BEAM ULTRA

MANUAL

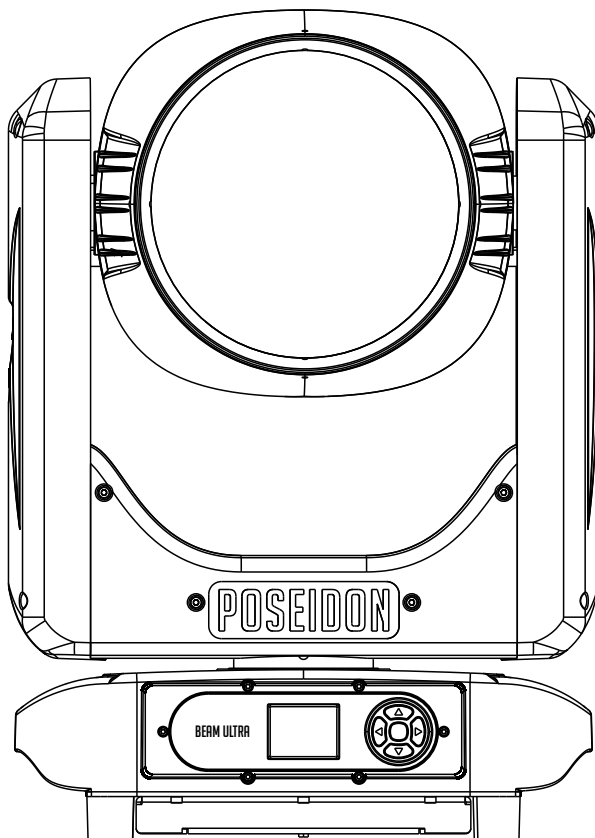
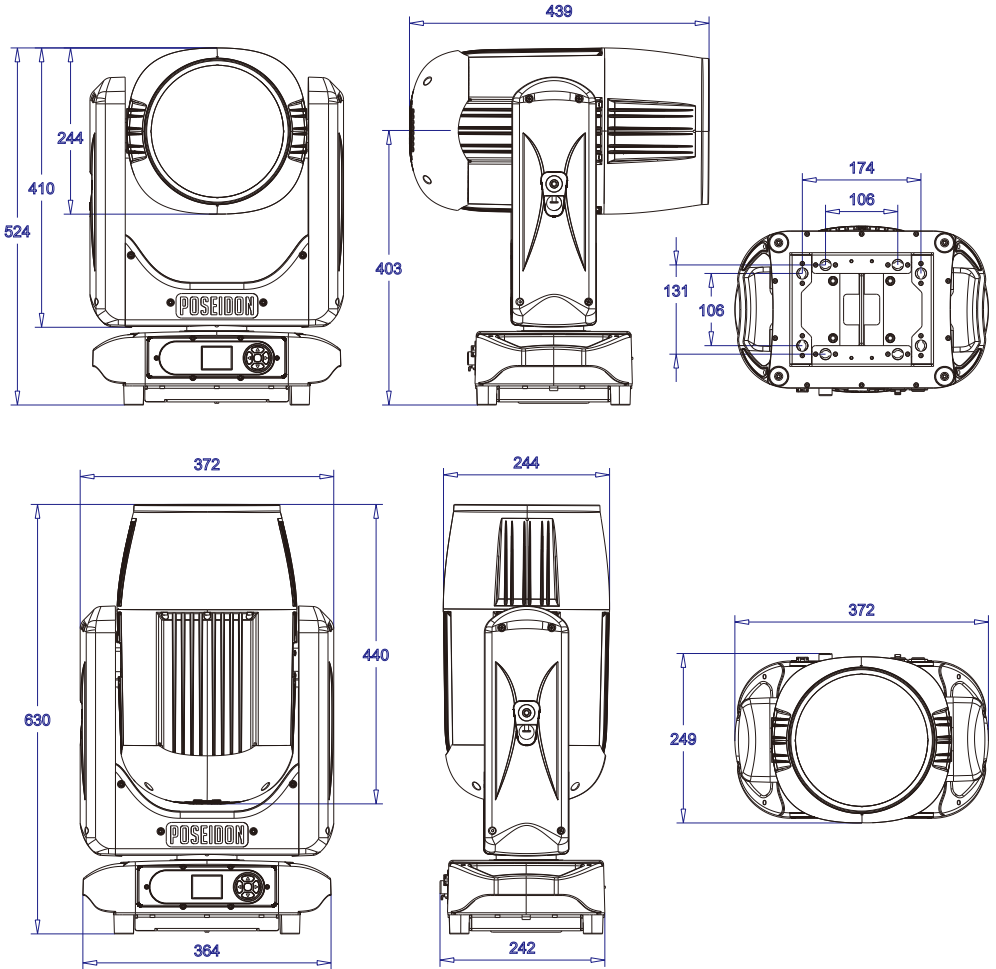

TABLE OF CONTENTS

Dimensions	1
Safety instruction	2
Protection from burns and fire	3
Protection from injury	3
Lamp life	3
Fixture overview	4
Introduction	5
Powerful outdoor beam ultra	5
Using for the first time	5
AC Power	5
Power voltage	5
Power cables	6
Relaying power to other devices	6
Data link	6
Tips for reliable data transmission	6
Physical installation	7
Fastening the fixture to a flat surface	7
Rigging via omega bracket	8
Outdoor IP-rated fixtures	9
Condensation/moisture inside housing	9
Fixtures temperature specification	9
Temporary usage	9
Setup	10
Control panel and menu navigation	10
DMX address setting	10
W-DMX control	10
Onboard control menu	11
DMX protocol	14
Gobo overview	17
Photometrics	18
How to clean the front lens	19
Circuit connection diagram	20
Specifications	21

DIMENSIONS

ALL DIMENSIONS ARE IN MILLIMETERS



SAFETY INSTRUCTION



WARNING!
Read the safety precautions in this section before installing, powering, operating or servicing this product.

The following symbols are used to identify important safety information on the product and in this manual:



DANGER!
Safety hazard.
Risk of severe injury or death.



DANGER!
Hazardous voltage. Risk of lethal or severe electric shock.



WARNING!
Fire hazard.



WARNING!
LED light emission. Risk of eye injury.



WARNING!
Burn hazard. Hot surface. Do not touch.



WARNING!
Wear protective eyewear.



WARNING!
Refer to user manual.



Do not look into the beam at short distance of the of the product.
Do not view the light output with optical instruments or any device that may concentrate the beam.



This product is for professional use only. It is not for household use.
This product presents risks of severe injury or death due to fire and burn hazards, electric shock and falls.
Read this manual before installing, powering or servicing the fixture, follow the safety precautions listed below and observe all warnings in this manual and printed on the fixture. If you have questions about how to operate the fixture safely, please contact your supplier.



PROTECTION FROM ELECTRIC SHOCK



- Disconnect the fixture from AC power before removing or installing any cover or part.
- Always ground (earth) the fixture electrically.
- Use only a source of AC power that complies with local building and electrical codes and has both overload and ground-fault (earth-fault) protection.
- Before using the fixture, check that all power distribution equipment and cables are in perfect condition and rated for the current requirements of all connected devices.
- Power input and throughput cables must be rated 20A minimum, have three conductors 1.5 mm² (16 AWG) minimum conductor size and an outer cable diameter of 5 - 15 mm. Cables must be hard usage type (SJT or equivalent) and heat-resistant to 90°C minimum.
- Use only PowerCON TRUE 1® cable connectors to connect to power input sockets. Use only PowerCON TRUE1® cable connectors to connect to power throughput sockets.
- Isolate the fixture from power immediately if the power plug or any seal, cover, cable, or other component is damaged, defective, deformed, wet or showing signs of overheating. Do not reapply power until repairs have been completed.
- Refer any service operation not described in this manual to a qualified technician.
- Socket outlets used to supply fixture fixtures with power or external power switches must be located near the fixtures and easily accessible so that the fixtures can easily be disconnected from power.

PROTECTION FROM BURNS AND FIRE



- The exterior of the fixture becomes hot during use. Avoid contact by persons and materials. Allow the fixture to cool for at least 5 minutes before handling.
- Keep all combustible materials (e.g. fabric, wood, paper) at least 1 metres away from the fixture.
- Keep flammable materials well away from the fixture.
- Ensure that there is free and unobstructed airflow around the fixture.



- Do not illuminate surfaces within 12 metres of the fixture.
- Do not attempt to bypass thermostatic switches or fuses.
- If you relay power from one fixture to another using power throughout sockets, do not connect more than five fixtures in total to each other in an interconnected chain.
- Connect only other fixtures to fixture power throughout sockets.
- Do not stick filters, masks or other materials onto any optical component.
- Do not modify the fixture in any way not described in this manual.

PROTECTION FROM INJURY



- Fasten the fixture securely to a fixed surface or structure when in use. The fixture is not portable when installed.
- Ensure that any supporting structure and/or hardware used can hold at least 10 times the weight of all the devices they support.
- Allow enough clearance around the head to ensure that it cannot collide with an object or another fixture when it moves.



- Check that all external covers and rigging hardware are securely fastened.
- Block access below the work area and work from a stable platform whenever installing, servicing or moving the fixture.
- Do not operate the fixture with missing or damaged covers, shields or any optical component.

LAMP LIFE



- Lamp life can vary, caused by many factors. For example external temperature, humidity, lamp strikes, dimming or power/voltage.

FIXTURE OVERVIEW

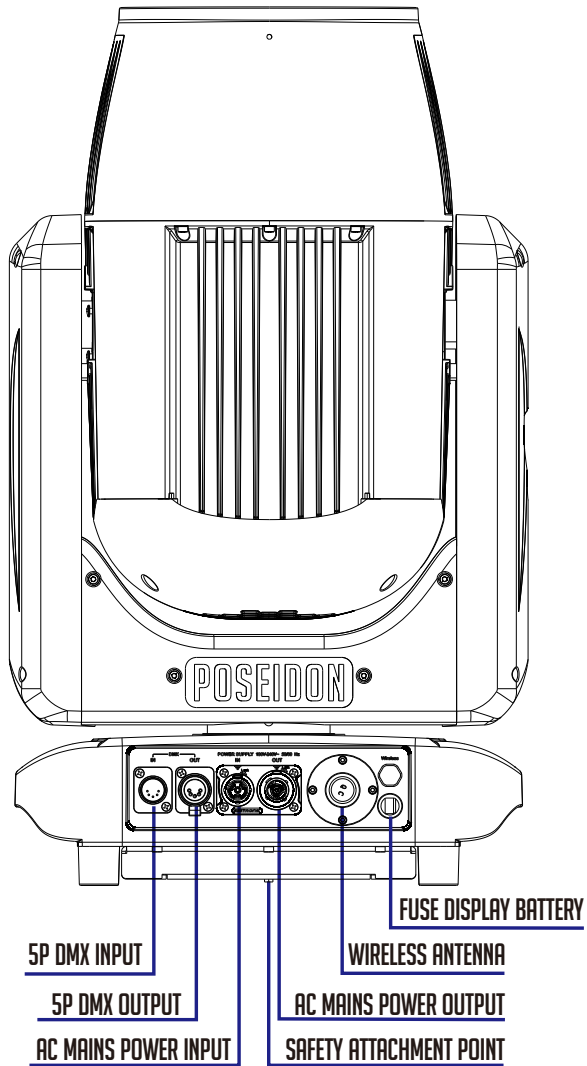

INTRODUCTION

POWERFUL OUTDOOR BEAM ULTRA

- IP65 DUST AND WATER PROTECTION
- 200MM LENS FOR 1.6° BEAM
- CMY AND COLOR WHEEL
- GOBO WHEEL, FROST AND 2 PRISMS
- LIGHT WEIGHT SLIM HOUSING

USING FOR THE FIRST TIME



Warning! Read “Safety Information” before installing, powering, operating or servicing the fixture.
Before applying power to the fixture:

Check that the local AC mains power source is within the fixture’s power voltage and frequency ranges.

See “Power cables and power plug” on page 6. Install a PowerCON TRUE1 ® power input connector power cable.

AC POWER



Warning! Read “Safety Information” starting on before connecting the fixtures to AC mains power.

Warning! For protection from electric shock, the fixture must be grounded (earthed). The power distribution circuit must be equipped with a fuse or circuit breaker and ground-fault (earth-fault) protection.

Warning! Socket outlets or external power switches used to supply the fixture with power must be located near the fixture and easily accessible so that the fixtures can easily be disconnected from power.



Important! Do not insert or remove live PowerCON TRUE 1 ® connectors to apply or cut power, as this may cause arcing at the terminals that will damage the connectors.

Important! Do not use an external dimming system to supply power to the fixture, as this may cause damage to the fixture that is not covered by the product warranty.

The fixture can be hard wired to a electrical installation if you want to install it permanently, or a power plug that is suitable for the local power outlets can be installed on the power cable.

POWER VOLTAGE



Warning! Check that the voltage range specified on the fixture serial number label matches the local AC mains power voltage before applying power to the fixture.

The fixtures accepts AC mains power at 100-240V nominal, 50/60 Hz. Do not apply AC mains power to the fixture at any other voltage than specified.



Warning! This product contain a ni-mh battery

POWER CABLES

Power input and throughput cables must be rated 16A minimum, have three conductors 1.5 mm² (16 AWG) minimum conductor size and an outer cable diameter of 5 - 15 mm. Cables must be hard usage type (SJT or equivalent) and heat-resistant to 90°C minimum. In the EU the cable must be HAR approved or equivalent.

If you install a power plug on the power cable, install a grounding-type (earthed) plug that is rated 16A minimum. Follow the plug manufacturer's instructions. Table 1 shows standard wire color-coding schemes and some possible pin identification schemes; if pins are not clearly identified.



Wire Color (EU models)	Wire Color (US models)	Conductor	Symbol
Brown	Black	Live	L
Blue	White	Neutral	N
Yellow/Green	Green	Ground (earth)	 or 

Table 1: Wire color-coding and power connections

RELAYING POWER TO OTHER DEVICES

Warning! Do not connect more than four fixtures in total in one interconnected chain. Power can be relayed to another device via the PowerCON TRUE 1 ® throughput socket.

If you daisy chain the fixtures in a chain so that they all draw AC mains power via the first fixture, certain points must be respected:

A heavy duty, three-conductor, 16 AWG or 1.5 mm² cable with SJT or equivalent cable jacket must be used to connect the first fixture to AC mains power. PowerCON TRUE1 ® connectors must be used to draw AC mains power from the fixtures power throughput socket and yellow PowerCON TRUE 1 ® connectors must be used to supply power at the fixture's power input sockets.

DATA LINK

A DMX 512 data link is required in order to control a fixture via DMX. The fixture has 5-pin XLR connectors for DMX data input and output. The pin-out on all connectors is pin 1 = shield, pin 2 = cold (-), and pin 3 = hot (+) Pins 4 and 5 in the 5-pin XLR connectors are not in use.

TIPS FOR RELIABLE DATA TRANSMISSION

To connect the fixture to data:

1. Connect the DMX data output from the controller to the 5-pin XLR connector of the nearest fixture.
2. Connect the DMX output of the first fixture to the DMX input of the next fixture and continue connecting fixtures.

PHYSICAL INSTALLATION



Warning! The fixture must be either fastened to a flat surface such as a stage or wall, or clamped to a truss or similar structure in any orientation using a rigging clamp.

Warning! Always attach an approved safety cable to one of the safety cable attachment points on the base.

Do not illuminate surfaces within 12 meters of the fixture. Ensure that flammable materials (wood, fabric, paper, etc.) are minimum 1 meters from the fixture and allow a free airflow around the fixture.

FASTENING THE FIXTURE TO A FLAT SURFACE

The fixture can be fastened to a fixed flat surface that is oriented at any angle. Check that the surface can support at least 10 times the weight of all fixtures and equipment to be installed.



Warning! The supporting surface must be hard and flat or cooling may be blocked, which will cause overheating. Fasten the fixture securely. Do not place it on unstable surfaces. Always attach a securely anchored safety cable to the safety cable attachment point.

1. Block access under the work area. Working from a stable platform, hang the fixture on the truss with the arrow on the base towards the area to be illuminated. Tighten the rigging clamp.
2. Secure the fixture against clamp failure with a secondary attachment such as an approved safety cable that is rated for the weight of the fixture using one of the attachment points at the edges of the base (see "Fixture overview"). Do not use any other part of the fixture as a safety cable attachment point.

The installation of the fixture has to be built and constructed in a way that it can hold 10 times the weight for 1 hour without any harming deformation.

The installation must always be secured with a secondary safety attachment, e.g. an appropriate catch net. This secondary safety attachment must be constructed in a way that no part of the installation can fall down if the main attachment fails.

When rigging, derigging or servicing the fixture staying in the area below the installation place, on bridges, under high working places and other endangered areas is forbidden.

The operator has to make sure that safety-relating and machine-technical installations are approved by an expert before taking into operation for the first time and after changes before taking into operation another time.

The operator has to make sure that safety-relating and machine-technical installations are approved by an expert after every four year in the course of an acceptance test.

The operator has to make sure that safety-relating and machine-technical installations are approved by a skilled person once a year.

The fixture should be installed outside areas where persons may walk by or be seated.

IMPORTANT! OVERHEAD RIGGING REQUIRES EXTENSIVE EXPERIENCE, including (but not limited to) calculating working load limits, installation material being used, and periodic safety inspection of all installation material and the projector. If you lack these qualifications, do not attempt the installation yourself, but instead use a professional structural rigger. Improper installation can result in bodily injury or damage to property. The fixture has to be installed out of the reach of people.



If the fixture shall be lowered from the ceiling or high joists, professional trussing systems have to be used. The fixture must never be fixed swinging freely in the room.

Caution: Fixture may cause severe injuries when crashing down! If you have doubts concerning the safety of a possible installation, do not install the moving head!

Before rigging make sure that the installation area can hold a minimum point load of 10 times the fixture's weight.

When installing the device, make sure there is no highly inflammable material (decoration articles, etc.) in a distance of min. 1m.

Use an appropriate clamp to rig the fixture on the truss.

Follow the instructions mentioned at the bottom of the base.

Make sure that the device is fixed properly! Ensure that the structure (truss) to which you are attaching the fixtures is secure.



The fixture can be placed directly on the stage floor or rigged on a truss without altering its operation characteristics .

For securing the fixture to the truss, install a safety wire which can hold at least 10 times the weight of the fixture. Use only the safety wire with a snap hook with screw lock gate. Fasten the safety cable in the attachment point and around the truss as shown on the picture below.

RIGGING VIA OMEGA BRACKET:

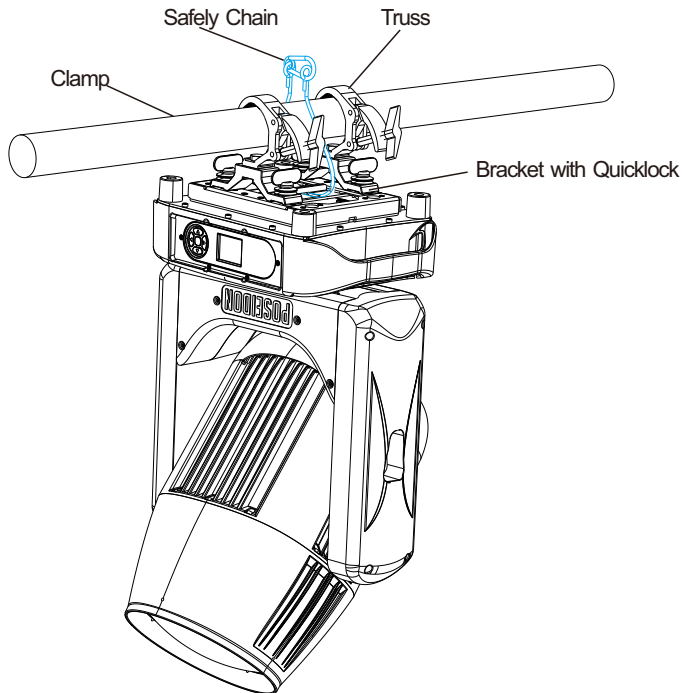

OUTDOOR IP-RATED FIXTURES

CLF products are applied to official classified IP norm levels. For this product the IP rate is IP65 when using the covers for the chassis parts. IP65 means according classified norm: shielded against dust and pressurized water from any side. Typical use for outdoor rated stage events with normal weather acceptance. So no heavy rain, because then the water pressure over exceeds the IP norm.



CONDENSATION/MOISTURE INSIDE HOUSING

Because of high humidity levels during production condensation can occur inside the housing. This is mostly visible on the coldest parts of the fixture, like the front glass or display. To prevent this problem we work with special conditioned areas for outdoor fixtures. Because of the breathing air valves it is still possible to get humidity inside the fixture. This will evaporate slowly. Do not put wet fixtures in a flightcase, this will help humidity enter the fixture.

FIXTURES TEMPERATURE SPECIFICATION

Make sure the fixture is used within its working temperature range. Outside this range we cannot guarantee correct operation.

TEMPORARY USAGE:

Stage event equipment is designed for temporary outdoor use. Materials are not designed for long-term exposure to heavy weather conditions. Rubber covers will be negatively affected by long-term UV exposure and should be checked by qualified service technicians over time. Tightening screws too hard will negatively affect the IP-rating.

SETUP

Warning! Read "Safety Information" before installing, powering, operating the fixture.

CONTROL PANEL AND MENU NAVIGATION

The onboard control panel and backlit graphic display are used to adjust the DMX address, fixture settings (personality), service utilities. See "Onboard control menus" for a complete list of menus and commands.

Using the control buttons:

- To enter the menu select [ENTER].
- Press [UP], [DOWN], [LEFT] AND [RIGHT] to scroll within a menu or adjust values.
- To enter a menu, select a function or apply a selection, press [ENTER].
- To escape a function or move back one level in the menu structure, press [LEFT].

DMX ADDRESS SETTING

The DMX address is the first channel used to receive instructions from the controller. For independent control, each fixture must be assigned to a separate channel. The DMX address can be configured by using the DMX ADDRESS menu in the control panel.

- NO DMX: Display flashes and shows at 'DMX: X'.
- DMX: Display backlight turns off and shows 'DMX: V'.
- The fixture is fully RDM ready. For RDM functions please refer to the ANSI/ESTA E1.20-2006 standard.

W-DMX CONTROL

This is an invisible menu. This menu will only be displayed when a wireless module is inserted.

Do not use Wireless DMX and Wired DMX at the same time because it will give unwanted interference.

- When this sign appears, it means: Connected Transmitter and Wireless DMX Connect. "  : ✓ ✓ "
- When this sign appears, it means: Connected Transmitter, No wireless DMX. "  : ✓ X "
- When this sign appears, it means: Not found transmitter and No wireless DMX. "  : X X "
- When this sign appears, it means: Wireless off. "  : off "

ONBOARD CONTROL MENU

Main menu	Menu level 1	Menu level 2	Menu level 3	Menu level 4
DMX Address	Address:001-512	Address(***-***) (Default:001)		
	DMX Signal mode	Wire -- WDMX OFF(Default) Wireless -- WDMX ON		
	Return(ESC)			
Information	Power hours	Total Hours: ***(H) Rst Hours: ***(H)		
	Lamp hours	Total Hours: ***(H) Rst Hours: ***(H)		
	Lamp strikes	Total Strikes: *** Rst Strikes: ***		
	Temperature	E-ballast:000.0 In TEMP :000.0		
	Logged temperature	E-ballast		Cur TEMP: *** Max TEMP: *** Min TEMP: ***
		In temperature		Cur TEMP: *** Max TEMP: *** Min TEMP: ***
		Return(ESC)		
	Fan information	Lamp fan		1.Power1:**.°V 2.Sp-Fan1:**.°% 3.Sp-Fan1:****R 4.Power2:**.°V 5.Sp-Fan2:**.°% 6.Sp-Fan3:**.°% 7.Sp-Fan2:****R 8.Sp-Fan3:****R
		Out fan		1.Power:**.°V 2.OutFan:**.°% 3.OutFan:****R
		In fan		1.Power1:**.°V 2.Power2:**.°V
Base fan			1.Power:**.°V 2.BaseFan1:**.°% 3.BaseFan2:**.°% 4.BaseFan1:****R 5.BaseFan2:****R	
Return(ESC)				
RDM UID	02E2:***** 1.Pan 000~255 2.Pan Fine 000~255 3.Tilt 000~255 4.Tilt Fine 000~255 5.P/T Speed 000~255 6.Function 000~255 7.Cyan 000~255 8.Magenta 000~255 9.Yellow 000~255 10.Color 000~255 11.FixGobo 000~255 12.Prism 000~255 13.Prism Rot 000~255 14.Prism2 000~255 15.Prism Rot2 000~255 16.Frost 000~255 17.Focus 000~255 18.Focus Fine 000~255 19.Shutter 000~255 20.Dimmer 000~255 21.Dimmer Fine 000~255			
DMX live				
System version		XY Board: V*.** CMY Board: V*.** FOCUS Board: V*.** FAN Board: V*.** DIS Board: V*.**		
Return(ESC)				
	Auto lamp on	OFF ON		
	Display lock	OFF ON		

Main	Menu level 1	Menu level 2	Menu level 3	Menu level 4	
Personal	Wireless options	Wireless ON/OFF	OFF		
		ON			
		wireless settings	Idle		
	P/T invert	wireless status	Unlink transmitter		
			Wireless off		
			Not found transmitte	No wireless DMX	
	Display	Pan invert	Connected Transmitte	No wireless DMX	
			Connected Transmitte	Wireless DMX Connect	
			Return(ESC)		
	P/T speed mode	Tilt invert	Backlight	OFF	
Rotat			ON		
Backlight blink			OFF		
CMY TV mode	Return(ESC)	Return(ESC)	ON		
		Normal			
		Fast			
Manual control	Channel control	Precise	Always on		
		OFF	Auto off (15s)		
		ON	Normal		
			Rotate 180		
			ON		
			OFF		
			1.Pan 000~255		
			2.Pan Fine 000~255		
			3.Tilt 000~255		
			4.Tilt Fine 000~255		
			5.P/T Speed 000~255		
			6.Function 000~255		
			7.Cyan 000~255		
			8.Magenta 000~255		
			9.Yellow 000~255		
			10.Color 000~255		
			11.FixGobo 000~255		
			12.Prism 000~255		
			13.Prism Rot 000~255		
			14.Prism2 000~255		
			15.Prism Rot2 000~255		
	16.Frost 000~255				
	17.Focus 000~255				
	18.Focus Fine 000~255				
	19.Shutter 000~255				
	20.Dimmer 000~255				
	21.Dimmer Fine 000~255				
	Return(ESC)				
Program Editor	Program Editor		Scene Edit	Sequence ***	
				1.Pan 000~255	
				2.Pan Fine 000~255	
				3.Tilt 000~255	
				4.Tilt Fine 000~255	
				5.P/T Speed 000~255	
				6.Function 000~255	
				7.Cyan 000~255	
				8.Magenta 000~255	
				9.Yellow 000~255	
		10.Color 000~255			
		11.FixGobo 000~255			
		12.Prism 000~255			
		13.Prism Rot 000~255			
		14.Prism2 000~255			
		15.Prism Rot2 000~255			
		16.Frost 000~255			
		17.Focus 000~255			
		18.Focus Fine 000~255			
		19.Shutter 000~255			
		20.Dimmer 000~255			
		21.Dimmer Fine 000~255			
		Save the scence			
		Return(ESC)			
		Static Scene:***			
		Time .*** SEC			
		Save the time			
		Return(ESC)			
		Static Scene:***			
		Time .*** SEC			
		Wait Time			

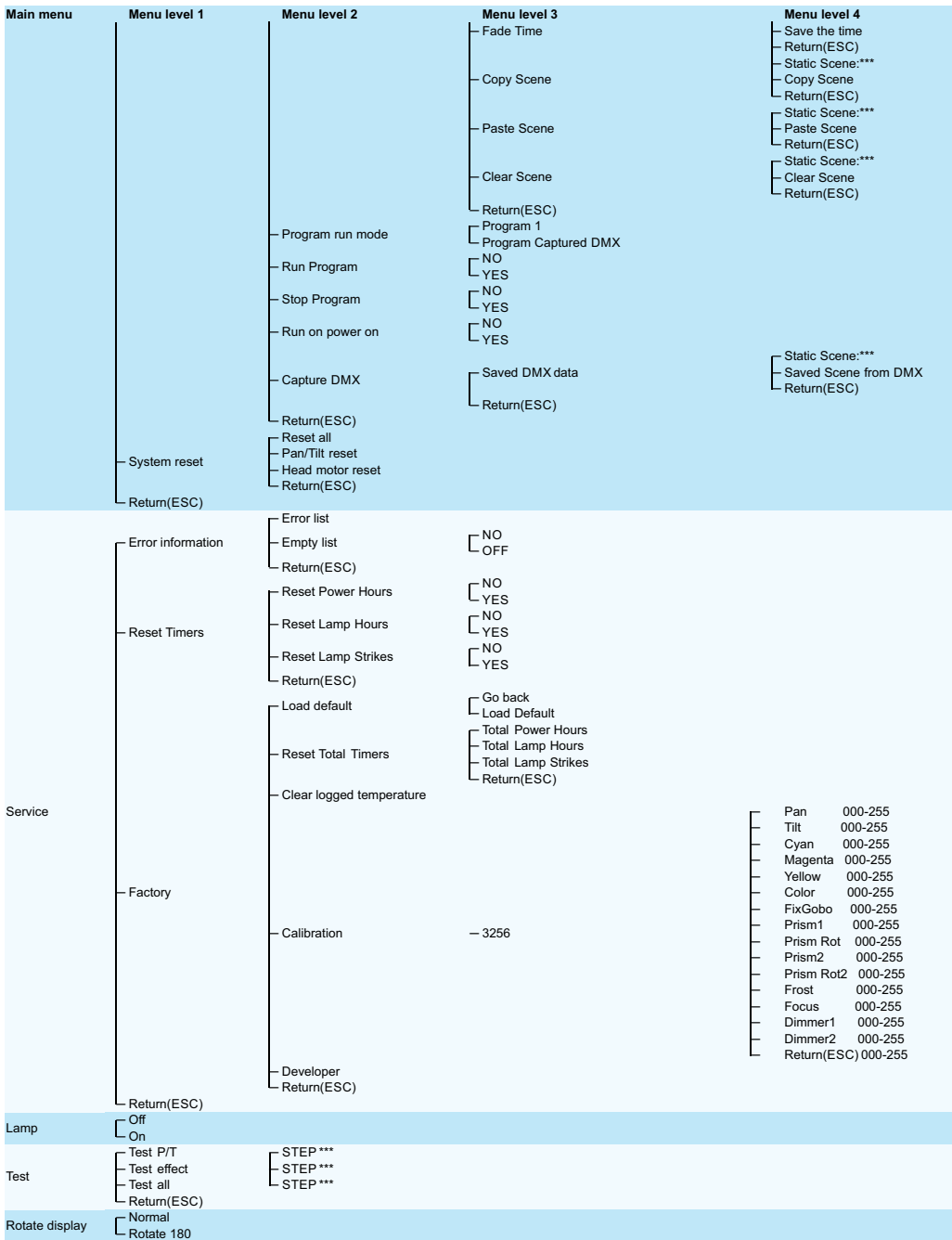

DMX PROTOCOL

CHANNEL	FUNCTION	VALUE	SETTING	NOTE
1	Pan	0-255	Pan	
2	Pan Fine	0-255	Pan Fine	
3	Tilt	0-255	Tilt	
4	Tilt fine	0-255	Tilt fine	
5	Pan/Tilt speed	0-255	Speed from max. to min	
6	Power/Special functions	0-9	Reserved (0=default)	
		10-14	Display lock off	
		15-19	Display lock on	* function is active only 3 seconds after switching the fixture on
		20-24	Display rotate normal	
		25-29	Display rotate 180°	
		30-34	Display backlight always on	
		35-39	Display backlight auto off(15s)	
		40-44	Display backlight blink off	
		45-49	Display backlight blink on	
		50-54	XY Normal mode	
		55-59	XY Fast mode	
		60-64	XY Precise mode	
		65-69	Reserved	
		70-74	CMY TV mode Off	
		75-79	CMY TV mode On	
		80-84	Auto lamp off at power-up	
		85-89	Auto lamp on at power-up	
		90-94	Reserved	
		95-99	Reserved	
		100-104	Pan invert off	
		105-109	Pan invert on	
		110-114	Tilt invert off	
		115-119	Tilt invert on	
		120-124	Reserved	
		125-129	Reserved	
		130 - 139	Lamp On	
		140 - 149	Pan/Tilt reset	
150 - 159	Head motor reset			
160 - 169	Total reset			
170 - 179	Reserved			
180 - 189	Reserved			
190 - 199	Reserved			
200 - 209	Reserved			
210 - 229	Reserved			
230 - 239	Lamp Off			
240 - 244	Reserved			
245 - 249	Reserved			
250 - 255	Reserved			
7	Cyan	0 - 255	Cyan from min. saturation --> full cyan (0=default)	
8	Magenta	0 - 255	Magenta from min. saturation --> full magenta (0=default)	
9	Yellow	0 - 255	Yellow from min. saturation --> full yellow (0=default)	
		0-4	White	
		5-8	White+Red	
		9-12	Red	
		13-17	Red+Orange	
		18-21	Orange	
		22-25	Orange+Aquamarine	
		26-29	Aquamarine	

CHANNEL	FUNCTION	VALUE	SETTING	NOTE
10	Colour	30-34	Aquamarine+Green	
		35-38	Green	
		39-42	Green+Light Green	
		43-46	Light Green	
		47-51	Light Green+Lavender	
		52-55	Lavender	
		56-59	Lavender+Pink	
		60-63	Pink	
		64-68	Pink+Yellow	
		69-72	Yellow	
		73-76	Yellow+Magenta	
		77-81	Magenta	
		82-85	Magenta+Cyan	
		86-89	Cyan	
		90-93	Cyan+CTO2	
		94-98	CTO2	
		99-102	CTO2+CTO1	
		103-106	CTO1	
		107-110	CTO1+CTB	
		111-115	CTB	
116-119	CTB+Blue			
120-123	Blue			
124-127	Blue+White			
128-191	CCW, Fast→Slow Rotation			
192-255	CW, Slow→Fast Rotation			
11	Static gobo wheel	0-3	Open/Hole (0=default)	
			Positioning	
		4-8	Beam reducer 1	
		9-13	Beam reducer 2	
		14-18	Gobo 1	
		19-23	Gobo 2	
		24-28	Gobo 3	
		29-33	Gobo 4	
		34-38	Gobo 5	
		39-43	Gobo 6	
		44-48	Gobo 7	
		49-53	Gobo 8	
		54-58	Gobo 9	
		59-63	Gobo 10	
		64-68	Gobo 11	
		69-73	Gobo 12	
		74-78	Gobo 13	
		79-83	Gobo 14	
		84-88	Gobo 15	
			Shaking gobos from slow to fast	
	89-95	Beam reducer 1		
	96-102	Beam reducer 2		
	103-109	Gobo 1		
	110-116	Gobo 2		
	117-123	Gobo 3		
	124-130	Gobo 4		
	131-137	Gobo 5		
	138-144	Gobo 6		
	145-151	Gobo 7		
	152-158	Gobo 8		

CHANNEL	FUNCTION	VALUE	SETTING	NOTE
		159-165	Gobo 9	
		166-172	Gobo 10	
		173-179	Gobo 11	
		180-186	Gobo 12	
		187-193	Gobo 13	
		194-200	Gobo 14	
		201-207	Gobo 15	
			Rotating	
		208-227	Forwards gobo wheel rotation from fast to slow	
		228-229	No rotation	
		230-249	Backwards gobo wheel rotation from slow to fast	
		250-255	Auto random gobo selection from fast to slow	
12	Prism1	0-3	Open position/hole (0=default)	
			prism in	
		4-199	Prism 1	
		200-255	Shaking Prism from slow to fast	
		0	No function	
		1 - 63	Prism 1 indexing	
		64-127	Forwards prism rotation from fast to slow	
		128-191	Backwards prism rotation from slow to fast	
13	Prism1 indexing/rotation	192-207	from slow to fast 90°Swing	
		208-223	from slow to fast 180°Swing	
		224-239	from slow to fast 270°Swing	
		240-255	from slow to fast 360°Swing	
14	Prism2	0-3	Open position/hole (0=default)	
			prism in	
		4-199	Prism 2	
		200-255	Shaking Prism from slow to fast	
		0	No function	
		1 - 63	Prism 2 indexing	
		64-127	Forwards prism rotation from fast to slow	
		128-191	Backwards prism rotation from slow to fast	
15	Prism2 indexing/rotation	192-207	from slow to fast 90°Swing	
		208-223	from slow to fast 180°Swing	
		224-239	from slow to fast 270°Swing	
		240-255	from slow to fast 360°Swing	
16	Frost	0-3	Open (0=default)	
		4-128	100% Light Frost	
		129-255	Reserved	
17	Focus	0 - 255	Continuous adjustment from far to near (128=default)	
18	Focus Fine	0 - 255	Fine focusing (0=default)	
		0 - 31	Shutter closed	
		32 - 63	Shutter open (32=default)	
		64 - 95	Strobe-effect from slow to fast	
		96 - 127	Shutter open	
19	Shutter/ strobe	128 - 143	Opening pulse in sequences from slow to fast	
		144 - 159	Closing pulse in sequences from fast to slow	
		160 - 191	Shutter open	
		192 - 223	Random strobe-effect from slow to fast	
		224 - 255	Shutter open, Full lamp power	
20	Dimmer intensity	0 - 255	Dimmer intensity from 0% to 100% (0=default)	
21	Dimmer intensity - fine	0 - 255	Fine dimming (0=default)	

GOBO OVERVIEW

Color wheel

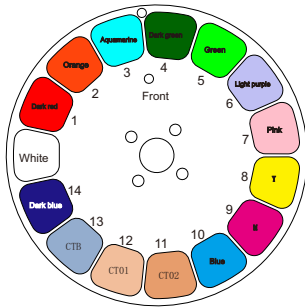

Static gobo wheel

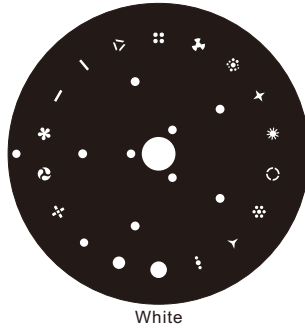

C

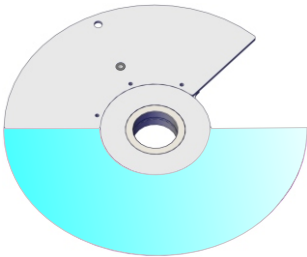

M

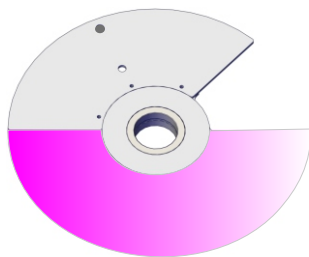

Y

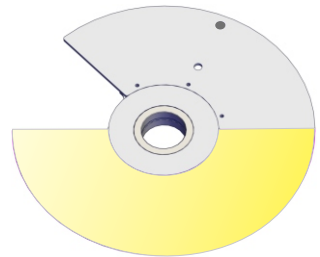

24 Prism

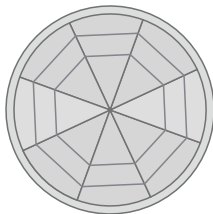

8 Prism

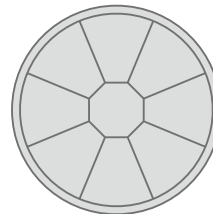

PHOTOMETRICS

distance, spot diameter and illumination diagram (Spot model)

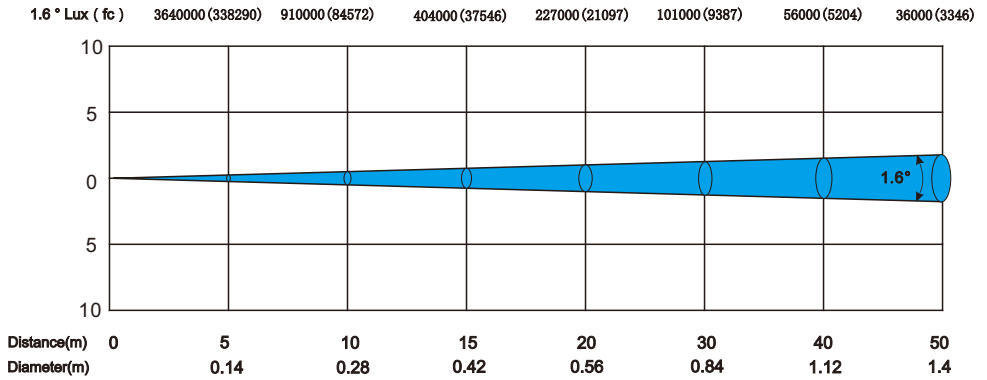

HOW TO CLEAN THE FRONT LENS

This is a detailed step-by-step guide on how to clean the front lens of a moving head fixture. If not clean properly the performance will negatively effected.

This is a good set of instructions, and it emphasizes the importance of using the right cleaning solution, the soaking method, careful drying, and avoiding wiping the lens when there are water droplets present. Here's a summary for clarity:

Materials Needed:

- Neutral degrease cleaning detergent .(**No alcohol , No acetone**)
- Microfiber cloth.
- Clean water.
- Absorbent cloth or paper towel.

Cleaning Steps:

1.Prepare Cleaning Solution:

- Dilute the cleaning detergent with water to a concentration of 0.2% to 0.5% (200-500 times dilution).

2.Soaking Cleaning Method:

- Pour the diluted cleaning detergent onto the front lens cover, covering 1-2CM of the lens glass.
- Gently wipe the lens glass with a microfiber cloth.
- Soak for 2-5 minutes.
- Clean the front lens with running water.
- Leave about 200ML of clean water in the lens and pour it out slowly to minimize water droplets on the lens.

3.Shake Out Remaining Water:

- After pouring out the water, gently shake the device up and down to remove any remaining water in the gaps of the lens.

4.Absorb Water Droplets:

- If there are water droplets on the lens after cleaning, do not wipe the lens surface.
- Use an absorbent cloth or paper towel to gently absorb the water droplets.

5.Natural Drying:

- Confirm that the lens surface is clean.
- Allow the lens to dry naturally for about 4 hours before reinstalling the device.
- If cleaning is not satisfactory, repeat step 2.

Remember to follow the manufacturer's guidelines for cleaning and maintenance if available, as different devices may have specific recommendations. Additionally, be cautious not to damage the lens coating or other delicate components during the cleaning process.

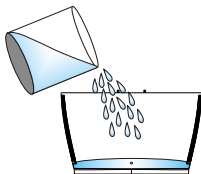

Pour the diluted cleaning detergent onto the front lens cover, covering 1-2CM of the lens glass , Soak for 2-5 minutes.

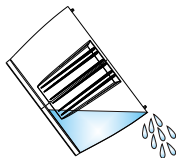

Leave about 200ML of clean water in the lens and pour it out slowly to minimize water droplets on the lens.

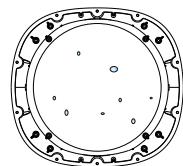

If there are water droplets on the lens after cleaning, do not wipe the lens surface. Use an absorbent cloth or paper towel to gently absorb the water droplets.

SPECIFICATIONS

Power	
Input voltage & rate	AC100-240V~, 50/60HZ
Standby power	70W
Total power consumption(at nominal voltage 100V)	530W
Typical current (at nominal voltage 100V)	5.3A
Total power consumption(at nominal voltage 230V)	500W
Typical current (at nominal voltage 230V)	2.15A
Cos φ -	0.95
Power factor	0.958 (lamp on)
Power plug type	Seetronic powercon TRUE 1
Configuration	
Lamp	USHIONSL301
Expected Lifetime	2000 hours / normal
Lamp color temperature	7400K
CRI level	82 (Standard)
CCT Light Output	7360K
Dimming frequency	0-100%
Dimmer resolution	65536 (16Bit)
Optical	
Beam angle	Beam projection 1.6°
Photometric	
Output @10M	Beam mode 1.6°: 910000 lx
Output @50M	Beam mode 1.6°: 36000 lx
Effects	
Color Mixing	CMY
Color wheel	Fixed color wheel 14 + open
Static Gobo wheel	Fixed wheel 17 + open
Prism wheel	Linear prism + 8 face prism + 24 face prism
Focus	16 bit
Frost	6°
Dimmer	16 bit, 0 – 100%
Shutter	12Hz / second
Pan	540°
Tilt	270°
Heat management	
Forced ventilation with axial fans.Automatically adjust fan speed	
Cooling type	
MAX ambient temp (Ta max)	Ta max= 40°C
MIN ambient temp (Ta min)	Ta min= -20°C
MAX housing temp. (ta=25°C)	Tc = 57°C
MAX housing temp. (ta=40°C)	Tc = 62°C
Menu	
Auto program	Manual program and Auto test program
Static color	White
Manual calibration	Service→Calibration→Function (0-255)
Factory calibration	Yes
Strobe speed	0.5-12 times/second
Random strobe	0.5-12 times/second

Control

Control protocol	DMX512
DMX channel range	21
W-DMX	Wireless DMX512
ACN	No
DMX input connection	5-pin
Data input (artnet, SACN)	No

Hardware

Interface	LCD Display
Software upload method	Software upload method XLR, firmware upload tool

Installation

IP rating	IP65 (Use rubber power & data cover)
Orientation	Any

Housing

Safety attachment point	Bottom
Lock	Tilt lock

Physical

Net product weight	26.4Kg
Machine dimensions - length	372mm
Machine dimensions - depth	244mm
Machine dimensions - height	630mm
Carton size	475mmx325mmx750mm
Gross weight	29.9Kg

Accessories

Included items	Manual, Power cable, DMX cable, Safety cable
----------------	--

Approvals

Approved certifications	CE and RoHs.
-------------------------	--------------

Information

Article number	160050
----------------	--------



CLF POSEIDON BEAM ULTRA