

CLF hercules

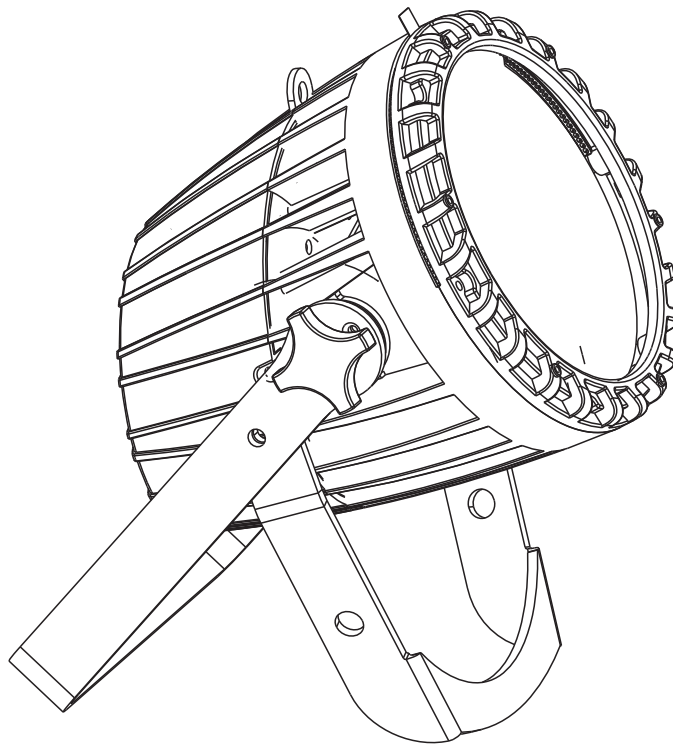

V 1.0 JANUARY 2015

Dimensions

All dimensions are in millimeters

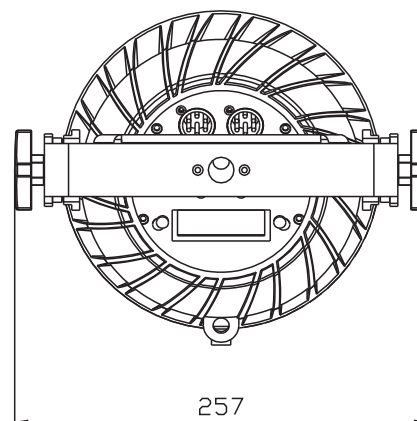
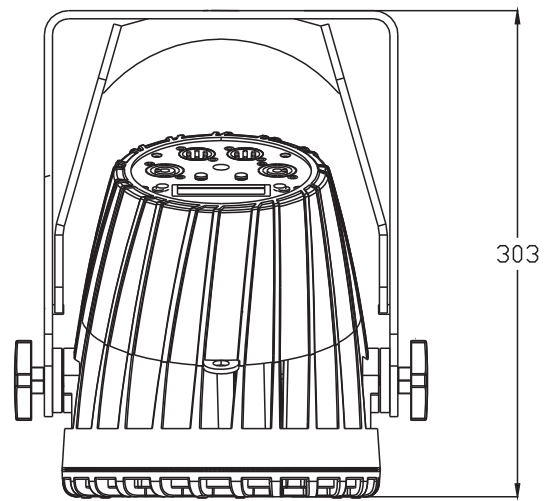
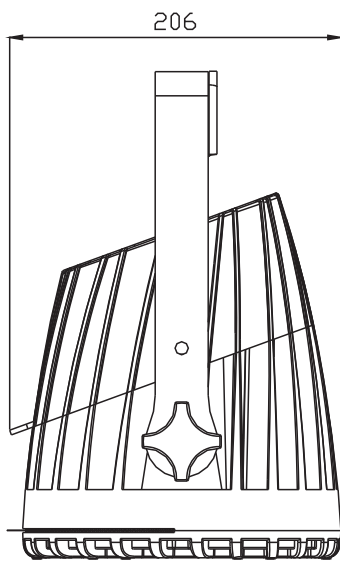

Safety Information



WARNING!

Read the safety precautions in this section before installing, powering, operating or servicing this product

The following symbols are used to identify important safety information on the product and in this manual:



DANGER!
Safety hazard.
Risk of severe injury or death.



DANGER!
Hazardous voltage. Risk of lethal or severe electric shock.



WARNING!
Fire hazard.



WARNING!
LED light emission. Risk of eye injury.



WARNING!
Burn hazard. Hot surface. Do not touch.



WARNING!
Wear protective eyewear.



WARNING!
Refer to user manual.



Warning! Risk Group 3 (high risk) LED product according to EN 62471. Do not look into the beam at a distance of less than 8.3 meters from the front surface of the product. Do not view the light output with optical instruments or any device that may concentrate the beam.

This product is for professional use only. It is not for household use.



This product presents risks of severe injury or death due to fire and burn hazards, electric shock and falls.

Read this manual before installing, powering or servicing the fixture, follow the safety precautions listed below and observe all warnings in this manual and printed on the fixture. If you have questions about how to operate the fixture safely, please contact your supplier



PROTECTION FROM ELECTRIC SHOCK

- Disconnect the fixture from AC power before removing or installing any cover or part and when not in use.
- Always ground (earth) the fixture electrically.
- Use only a source of AC power that complies with local building and electrical codes and has both overload and ground-fault (earth-fault) protection.
- Before using the fixture, check that all power distribution equipment and cables are in perfect condition and rated for the current requirements of all connected devices.
- Power input and through put cables must be 3-conductor, rated 20 A minimum, 1.5 mm² (16 AWG) minimum conductor size, Power input and through put cables must be 3-conductor, rated 20 A minimum, 1.5 mm² (16 AWG) minimum conductor size, extra hard usage type (ST or equivalent). The cable must be heat-resistant to 90° C (194° F) minimum.
- Use only PowerCon cable connectors to connect to power input sockets. Use only PowerCon cable connectors to connect to power throughput sockets.
- Isolate the fixture from power immediately if the power plug or any seal, cover, cable, or other component is damaged, defective, deformed, wet or showing signs of overheating. Do not reapply power until repairs have been completed.



- Do not expose the fixture to rain or moisture.
- Refer any service operation not described in this manual to a qualified technician.
- Socket outlets used to supply fixture fixtures with power or external power switches must be located near the fixtures and easily accessible so that the fixtures can easily be disconnected from power.

PROTECTION FROM BURNS AND FIRE



- Do not operate the fixture if the ambient temperature (T_a) exceeds 40°C (104°F).
- The exterior of the fixture becomes hot during use. Avoid contact by persons and materials. Allow the fixture to cool for at least 10 minutes before handling.



- Keep all combustible materials (e.g. fabric, wood, paper) at least 100 mm (3.9 in.) away from the head.
- Keep flammable materials well away from the fixture.
- Ensure that there is free and unobstructed airflow around the fixture.
- Do not illuminate surfaces within 200 mm (7.9 ins.) of the fixture.
- Do not attempt to bypass thermostatic switches or fuses.
- If you relay power from one fixture to another using power throughput sockets, do not connect more than ten fixture fixtures in total to each other in an interconnected chain.
- Connect only other fixture fixtures to fixture power throughput sockets. Do not connect any other type of device to these sockets.
- Do not stick filters, masks or other materials onto any optical component.
- Do not modify the fixture in any way not described in this manual

PROTECTION FROM INJURY



- Do not look continuously at LEDs from a distance of less than 8.3 meters (27 ft. 3 inches) from the front surface of the fixture without protective eyewear such as shade 4-5 welding goggles. At less than this distance, the LED emission can cause eye injury or irritation. At distances of 8.3 meters (27 ft. 3 inches) and above, light output is harmless to the naked eye provided that the eye's natural aversion response is not overcome.



- Do not look at LEDs with magnifiers, telescopes, binoculars or similar optical instruments that may concentrate the light output.



- Ensure that persons are not looking at the LEDs from within 8.3 meters (27 ft. 3 inches) when the product lights up suddenly. This can happen when power is applied, when the product receives a DMX signal, or when SERVICE menu items are selected.

- Fasten the fixture securely to a fixed surface or structure when in use. The fixture is not portable when installed.
- Ensure that any supporting structure and/or hardware used can hold at least 10 times the weight of all the devices they support.
- Allow enough clearance around the head to ensure that it cannot collide with an object or another fixture when it moves.
- Check that all external covers and rigging hardware are securely fastened.
- Block access below the work area and work from a stable platform whenever installing, servicing or moving the fixture.
- Do not operate the fixture with missing or damaged covers, shields or any optical component.

Contents

Dimensions	2
Safety Information	3
Fixture overview	6
Introduction	7
Using for the first time	7
AC power	8
Power voltage	8
Power cables and power plug	8
Relaying power to other devices	9
Data link	9
Connecting the data link	9
Tips for reliable data transmission	9
Physical installation	10
Fastening the fixture to a flat surface	10
Setup	11
Control panel and menu navigation	11
DMX address setting	11
WDMX control	11
Control mode	12
Dimming	12
Restoring factory default settings	12
Operation and effects	12
Effects	12
Filter sheet	13
Service and maintenance	14
Cleaning	14
DMX protocol	15
Onboard control menus	17
Specifications	18

Fixture overview

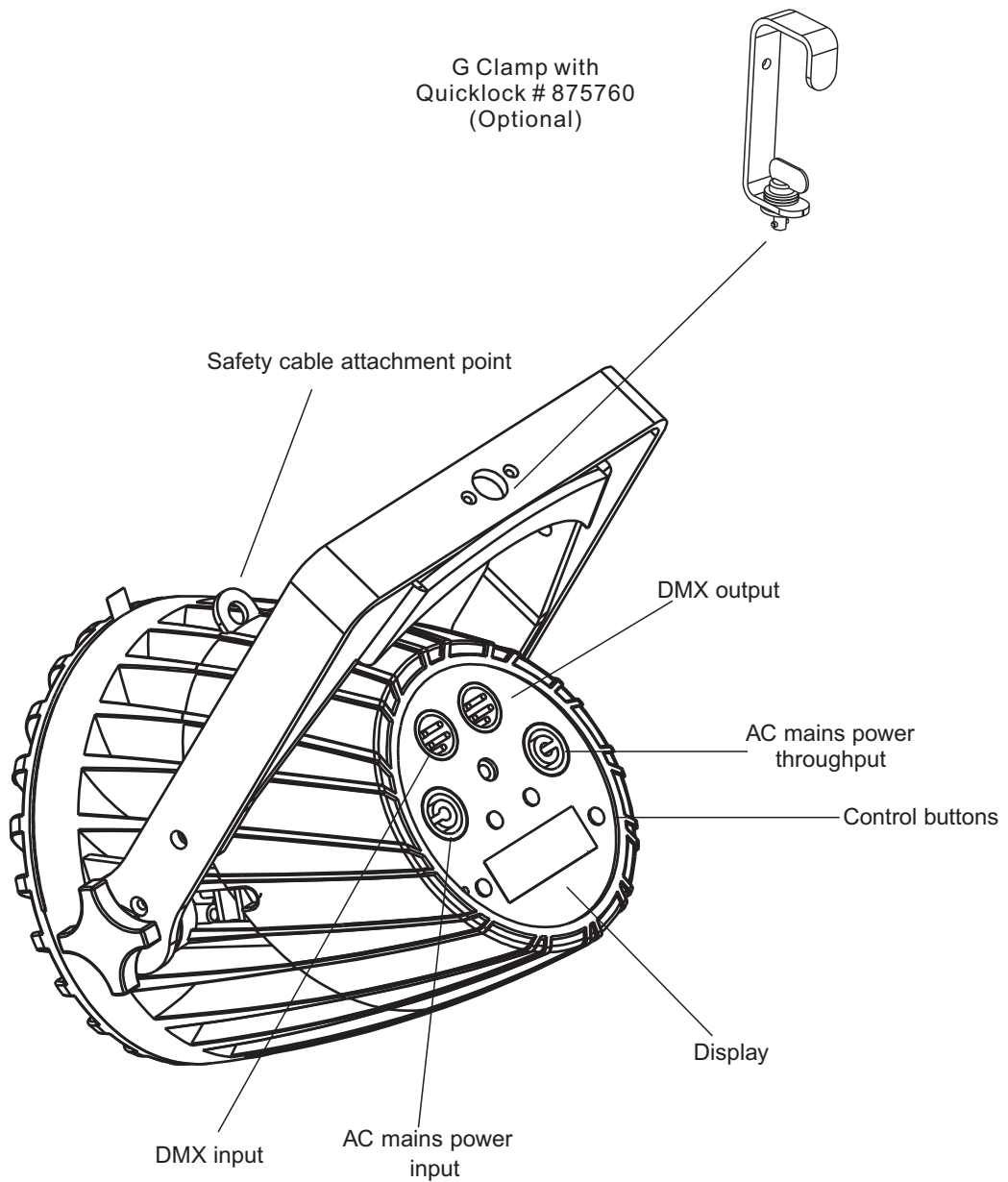

Note: head fan grill in production models is rotated 90° compared to this illustration.

Introduction

- This compact LED-based Parcan features:
- RGBW color control with color temperature control
- 6 in 1 LED (Red,Green,Blue,White,Amber,Purple)
- Onboard control panel and backlit LCD graphic display
- Smooth electronic dimming
- Electronic shutter with strobe and pulse effects
- DMX control
- choose different degrees of filter sheet to change the shape of the light

Using for the first time



Warning! Read “Safety Information” on page 3 before installing, powering, operating or servicing the fixture. Before applying power to the fixture:.

- Carefully review “Safety Information” starting on page 3.
- Check that the local AC mains power source is within the fixture's power voltage and frequency ranges.
- See “Power cables and power plug” on page 8. Install a PowerCon power input connector on a suitable power cable. If drawing power from a mains power outlet, install a suitable power plug on the power cable.

AC power



Warning! Read "Safety Information" starting on page 3 before connecting the fixtures to AC mains power.

Warning! For protection from electric shock, the fixture must be grounded (earthed). The power distribution circuit must be equipped with a fuse or circuit breaker and ground-fault (earth-fault) protection.



Warning! Socket outlets or external power switches used to supply the fixture with power must be located near the fixture and easily accessible so that the fixtures can easily be disconnected from power.

Important! Do not insert or remove live PowerCon connectors to apply or cut power, as this may cause arcing at the terminals that will damage the connectors.

Important! Do not use an external dimming system to supply power to the fixture, as this may cause damage to the fixture that is not covered by the product warranty.

The fixture can be hard-wired to a building electrical installation if you want to install it permanently, or a power plug that is suitable for the local power outlets can be installed on the power cable.

Power voltage



Warning! Check that the voltage range specified on the fixture's serial number label matches the local AC mains power voltage before applying power to the fixture.

The fixtures accept AC mains power at 100-240 V nominal, 50/60 Hz. Do not apply AC mains power to the fixture at any other voltage than that specified on the fixture's serial number label.

Power cables and power plug

Power input and throughput cables must be rated 20 A minimum, have three conductors 1.5 mm² (16 AWG) minimum conductor size and an outer cable diameter of 5 - 15 mm (0.2 - 0.6 in.). Cables must be hard usage type (SJT or equivalent) and heat-resistant to 90° C (194° F) minimum. In the EU the cable must be HAR approved or equivalent.

If you install a power plug on the power cable, install a grounding-type (earthed) plug that is rated 20 A minimum. Follow the plug manufacturer's instructions. Table 1 shows standard wire color-coding schemes and some possible pin identification schemes; if pins are not clearly identified, or if you have any doubts



Wire Color (EU models)	Wire Color (US models)	Conductor	Symbol	Screw (US)
brown	black	live	L	yellow or brass
blue	white	neutral	N	silver
yellow/green	green	ground (earth)	 or 	green

Table 1: Wire color-coding and power connections

Relaying power to other devices



Warning! Do not connect more than ten fixture fixtures in total to AC mains power in one interconnected chain

Power can be relayed to another device via the light-grey PowerCon throughput socket that accepts a light-grey PowerCon cable connector. Note that blue input and light-grey throughput connectors have different designs: one type cannot be connected to the other.

If you link fixtures in a chain so that they all draw AC mains power via the first fixture, certain points must be respected:

- A hard usage, three-conductor, 16 AWG or 1.5 mm² cable with SJT or equivalent cable jacket must be used to connect the first fixture to AC mains power and to interconnect all the fixtures in the chain up to a maximum of seven fixtures in total.
- Light-grey PowerCon connectors must be used to draw AC mains power from the fixtures' power throughput sockets and blue PowerCon connectors must be used to supply power at the fixture's power input sockets.
- No matter what the AC mains power voltage is, do not connect more than ten fixture fixtures in total (i.e. including the first fixture) to AC mains power in one interconnected daisy chain using power input and throughput connectors.

Data link

A DMX 512 data link is required in order to control a fixture via DMX.

The fixture has 3-pin XLR connectors for DMX data input and output. The pin-out on all connectors is pin 1 = shield, pin 2 = cold (-), and pin 3 = hot (+).

Or the fixture has 5-pin XLR connectors for DMX data input and output. The pin-out on all connectors is pin 1 = shield, pin 2 = cold (-), and pin 3 = hot (+). Pins 4 and 5 in the 5-pin XLR connectors are not used

Connecting the data link

To add more fixtures or groups of fixtures when the above limit is reached, add a DMX universe and another daisy-chained link.

Use shielded twisted-pair cable designed for RS-485 devices: standard microphone cable cannot transmit control data reliably over long runs. 24 AWG cable is suitable for runs up to 300 meters. Heavier gauge cable and/or an amplifier is recommended for longer runs.

Tips for reliable data transmission

To connect the fixture to data:

1. Connect the DMX data output from the controller to the closest fixture's male 3-pin XLR DMX input connector.
2. Connect the DMX output of the fixture closest to the controller to the DMX input of the next fixture and continue connecting fixtures output to input.

Physical installation



Warning! The fixture must be either fastened to a flat surface such as a stage or wall, or clamped to a truss or similar structure in any orientation using a rigging clamp. Do not apply power to the fixture if it is standing freely or the fixture can be moved.

Warning! If the fixture can cause injury or damage if it falls, attach an approved safety cable to one of the safety cable attachment points on the base (see “Fixture overview” on page 6).

Check that all surfaces to be illuminated are minimum 200 mm. from the fixture, that combustible materials (wood, fabric, paper, etc.) are minimum 100 mm. from the head, that there is free airflow around the fixture and that there are no flammable materials nearby.

Make sure that it is impossible for the moving head to collide with another fixture or other object...

Fastening the fixture to a flat surface

The fixture can be fastened to a fixed flat surface that is oriented at any angle. Check that the surface can support at least 10 times the weight of all fixtures and equipment to be installed on it.



Warning! The supporting surface must be hard and flat or air vents in the base may be blocked, which will cause overheating. Fasten the fixture securely. Do not stand it on a surface or leave it where it can be moved or can fall over. Attach a securely anchored safety cable to the safety cable attachment point (see “Fixture overview” on page 6) if the fixture is to be installed in any location where it may fall and cause injury or damage if the primary attachment fails.

3. Block access under the work area. Working from a stable platform, hang the fixture on the truss with the arrow on the base towards the area to be illuminated. Tighten the rigging clamp.
4. Secure the fixture against clamp failure with a secondary attachment such as an approved safety cable that is rated for the weight of the fixture using one of the attachment points at the edges of the base (see “Fixture overview” on page 6). Do not use any other part of the fixture as a safety cable attachment point.
5. Check that the head will not collide with other fixtures or objects.

Setup



Warning! Read “Safety Information” on page 3 before installing, powering, operating or servicing the fixture.

Control panel and menu navigation

The onboard control panel and backlit graphic display are used to set the fixture's DMX address, configure individual fixture settings (personality), read out data and execute service utilities. See “Onboard control menus” on page 22 for a complete list of menus and commands.

Using the control buttons

- To enter a menu, select a function or apply a selection, press ► (Enter).
- Press ▲ (Up) and ▼ (Down) to scroll within a menu or adjust values.
- To escape a function or move back one level in the menu structure, press ◀ (MODE).
- Holding down the "UP" or "DOWN" button for more than 3 seconds, the MENU display rotated 180°

DMX address setting

The DMX address, also known as the start channel, is the first channel used to receive instructions from the controller. For independent control, each fixture must be assigned its own control channels.

The DMX address is configured using the DMX ADDRESS menu in the control panel.

- In order to facilitate for inspection the signal, If the display to flicker when it's not receiving any signalNotes

WDMX control

Press the button “UP” to switch off Wireless DMX or disconnect with all connected Transmitters.

Press the button “DOWN” to set the unit in the "ready to connect with all not connected transmitters" mode. If you press the mode button on the Wireless solution transmitter all the ready to connect units will be connected.

If the unit is successfully connected in the home display the sign “”. Appears. If the unit is not connected to a transmitter or switched off no “”. sign is visible

CONTROL MODE

Standard and **Manual** modes

DMX control mode is selected in the **CONTROL MODE** menu. The fixture has five DMX control modes:

- 6 channels :Red+Green+Blue+White+Amber+Purple
- 8 channels :Dimmer+Red+Green+Blue+White+Amber+Purple+ strobe
- 12 channels :Dimmer++Red+Green+Blue+White+Amber+Purple+ strobe+Macro + strobe + AUTO + AUTO speed+ dimming speed
- HSV: Hue+Saturation+Value
- HSI: Hue+Saturation+Intensity

Dimming

- **FAST** is the default setting. It gives a virtually instantaneous reaction when you dim from one intensity to another, but dimming slowly from one intensity to another may appear slightly uneven.
- The **SMOOTH** setting gives smoother dimming during slow changes in intensity, but it limits the speed of dimming changes slightly. This makes it ideal for slow, smooth dimming, but a short time-lag may be noticeable if you try to dim quickly from one intensity to another.

Restoring factory default settings

The fixture factory default settings can be restored by applying a **FACTORY SETTING** → **LOAD** command.

Operation and effects



Warning! Read "*Safety Information*" starting on page 3 before installing, powering, operating or servicing the fixture.

This section describes only DMX control features that require particular explanation. See "DMX protocols" on page 16 for a full list of the DMX channels and values required to control the different effects.

Effects

Shutter effect

The electronic 'shutter' effect available for the fixture provides instant open and blackout, variable speed regular and random strobe and opening/closing pulse effects as well as burst and sine wave effects.

Controlling color

Filter sheet

You can choose different degrees of filter sheet to change the shape of the light, and can change the Angle of the light rotating filter sheet

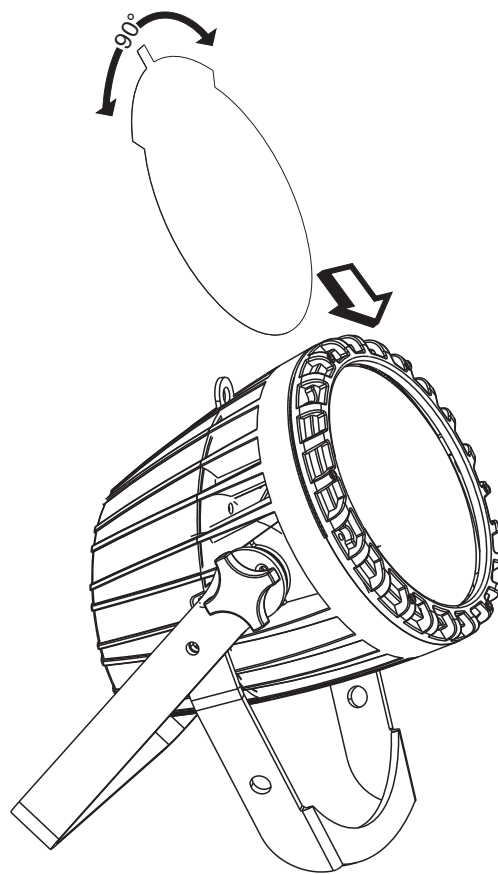

Service and maintenance

Warning! Read “Safety Information” on page 3 before servicing the fixture.



Warning! Disconnect the fixture from AC mains power and allow to cool for at least 10 minutes before handling. Do not view the light output from less than 8.3 meters (27 ft. 3 inches) without shade 4–5 welding goggles. Be prepared for the fixture to light suddenly if connected to power.

Warning! Refer any service operation not described in this user manual to a qualified service technician.



Important! Excessive dust, smoke fluid, and particle buildup degrades performance, causes overheating and will damage the fixture. Damage caused by inadequate cleaning or maintenance is not covered by the product warranty.



It is policy to apply the strictest possible calibration procedures and use the best quality materials available to ensure optimum performance and the longest possible component lifetimes. However, LEDs are subject to wear and tear over the life of the product, resulting in gradual changes in color and overall brightness over many thousands of hours of use. The extent of wear and tear depends heavily on operating conditions and environment, so it is impossible to specify precisely whether and to what extent LED performance will be affected. However, you may eventually need to ask Professional to replace LEDs if their characteristics are affected by wear and tear after an extended period of use and if you require fixtures to perform within very precise optical and color parameters.



The manufacturer’s LED lifetime data is based on performance under the manufacturer’s test conditions. As with all LEDs, the gradual reduction in luminous output will be accelerated when LEDs are used in a fixture, where conditions are much tougher than in manufacturer’s testing. To maximize LED lifetimes, keep the ambient temperature as low as possible and drive the LEDs no harder and for no longer than necessary

Cleaning

Cleaning schedules for lighting fixtures vary greatly depending on the operating environment. It is therefore impossible to specify precise cleaning intervals for the fixture. Environmental factors that may result in a need for frequent cleaning include:

- Use of smoke or fog machines.
- High airflow rates (near air conditioning vents, for example).
- Presence of cigarette smoke.
- Airborne dust (from stage effects, building structures and fittings or the natural environment at outdoor events, for example).

If one or more of these factors is present, inspect fixtures within their first 100 hours of operation to see whether cleaning is necessary. Check again at frequent intervals. This procedure will allow you to assess cleaning requirements in your particular situation.

Use gentle pressure only when cleaning, and work in a clean, well-lit area. Do not use any product that contains solvents or abrasives, as these can cause surface damage.



Warning! Disconnect from power and allow to cool before cleaning.

To clean the fixture:

1. Disconnect the fixture from power and allow it to cool for at least 10 minutes.
2. Vacuum or gently blow away dust and loose particles from the outside of the fixture and the air vents at the back and sides of the head and in the base with low-pressure compressed air.
3. Remove the central screw from the grill on the front of the head, remove the grill and clean the LED lenses by wiping gently with a soft, clean lint-free cloth moistened with a weak detergent solution. Do not rub the surface hard: lift particles off with a soft repeated press. Dry with a soft, clean, lint-free cloth or low-pressure compressed air. Remove stuck particles with an unscented tissue or cotton swab moistened with glass cleaner or distilled water.



DMX protocols

6-CH	8-CH	12-CH	DMX Value	Percent	Function
	1	1	0 - 255	0 - 100	Dimmer (0-100%)
1	2	2	0 - 255	0 - 100	Red(0-100%)
2	3	3	0 - 255	0 - 100	Green(0-100%)
3	4	4	0 - 255	0 - 100	Blue(0-100%)
4	5	5	0 - 255	0 - 100	White(0-100%)
5	6	6	0 - 255	0 - 100	Amber(0-100%)
6	7	7	0 - 255	0 - 100	Purple(0-100%)
					Electronic shutter effect
			0 - 19	0 - 7	Shutter closed
			20 - 24	8 - 9	Shutter open
			25 - 64	10 - 25	Strobe 1 (fast → slow)
			65 - 69	26 - 27	Shutter open
			70 - 84	28 - 33	Strobe 2: opening pulse (fast → slow)
			85 - 89	34 - 35	Shutter open
			90 - 104	36 - 41	Strobe 3: closing pulse (fast → slow)
			105 - 109	42 - 43	Shutter open
			110 - 124	44 - 49	Strobe 4: random strobe (fast → slow)
	8	8	125 - 129	50 - 51	Shutter open
			130 - 144	52 - 57	Strobe 5: random opening pulse (fast → slow)
			145 - 149	58 - 59	Shutter open
			150 - 164	60 - 65	Strobe 6: random closing pulse (fast → slow)
			165 - 169	66 - 67	Shutter open
			170 - 184	68 - 73	Strobe 7: burst pulse (fast → slow)
			185 - 189	74 - 75	Shutter open
			190 - 204	76 - 81	Strobe 8: random burst pulse (fast → slow)
			205 - 209	82 - 83	Shutter open
			210 - 224	84 - 89	Strobe 9: sine wave (fast → slow)
			225 - 229	90 - 91	Shutter open
			230 - 244	92 - 97	Strobe 10: burst (fast → slow)
			245 - 255	98 - 100	Shutter open
		9	0 - 10	0 - 4	No Function
			11 - 205	5 - 80	Macro color control
			206 - 255	81-100	Macro CCT control
		10	000-010	0 - 4	No Function
			011-060	5-23	Auto 01
			061-120	24-47	Auto 02
			121-180	48-70	Auto 03
			181-240	71-94	Auto 04
			241-255	95-100	Auto (01-04) circulation
		11	0-255	0-100	Auto speed (slow→ast)
		12	0-051	0-20	Preset dimmer speed from display menu
			52-101	21-40	Dimmer speed mode off
			102-152	41-60	Dimmer speed mode1 (fast speed)
			153-203	61-80	Dimmer speed mode2 (middle speed)
			204-255	81-100	Dimmer speed mode3 (slow speed)

3 channels: HSV

Channel	Value	Description
1	000~255	Hue
2	000~255	Saturation
3	000~255	Value (Intensity)

Note: In HSV mode, Hue stands for the visible light, such as red, yellow, and cyan, etc. Saturation refers to the dominance of hue in the color; when saturation is at 100%, then the color is at its purest. Value is the color's brightness; when value is at 100%, then the color is at its brightest.

3 channels: HSI

Channel	Value	Description
1	000~255	Hue
2	000~255	Saturation
3	000~255	Intensity

Onboard control menus

Menu	Item	Options	Notes (Default settings in bold print)
DMX ADDRESS		1-XXX	Set DMX start address
		6CH	6CHs:RGBWAP
CONTROL MODE		8CH	8CHs:Dimmer+RGBWAP+strobe
		12CH	12CHs:Dimmer+RGBWAP+strobe+Macro color+auto+auto speed + dimmer speed
		HSV	HSV: Hue+Saturation+Value
		HSI	HSI: Hue+Saturation+Intensity
STATIC COLOR	Dimmer	0~255	0~100%
	Red	0~255	0~100%
	Green	0~255	0~100%
	Blue	0~255	0~100%
	WHITE	0~255	0~100%
	Amber	0~255	0~100%
	Purple	0~255	0~100%
	STROBE	0~10	Select strobe frequency
AUTO	AUTO(1-10)	speed(0-20)	10 Auto programs available
	CUSTOM(1-10)		Choose custom programs
PERSONALITY	DIMMER SPEED	FAST	Fast dimming with unrestricted speed
		SMOOTH	Smooth dimming with restricted speed
	FANS	REGULATED	Cooling fan speed thermostatically regulated
		FULL	Max. cooling fan speed
	WDMX	ON	Turn on the Wireless
		OFF	Turn off the Wireless
		RESET	Reset the Wireless
	LED BOOST MODE	ON	single leds in full power with 120% current, when color mix will drop to 100% current
OFF			
SCENE EDITOR	Custome (1~10) Scene (1~30)	Red	0-255
		Green	0-255
		Blue	0-255
		WHITE	0-255
		Amber	0-255
		Purple	0-255
		STROBE	(0~20Hz)Select strobe frequency
		Fade	step time(XXX s)
		Time	transition time of last step to current step(XXX s)
INFO	VERSION	V1.0	Use time reset
	TEMP	XXX°C	LEDs current temperature
FACTORY SET		LOAD	Return all settings to factory defaults

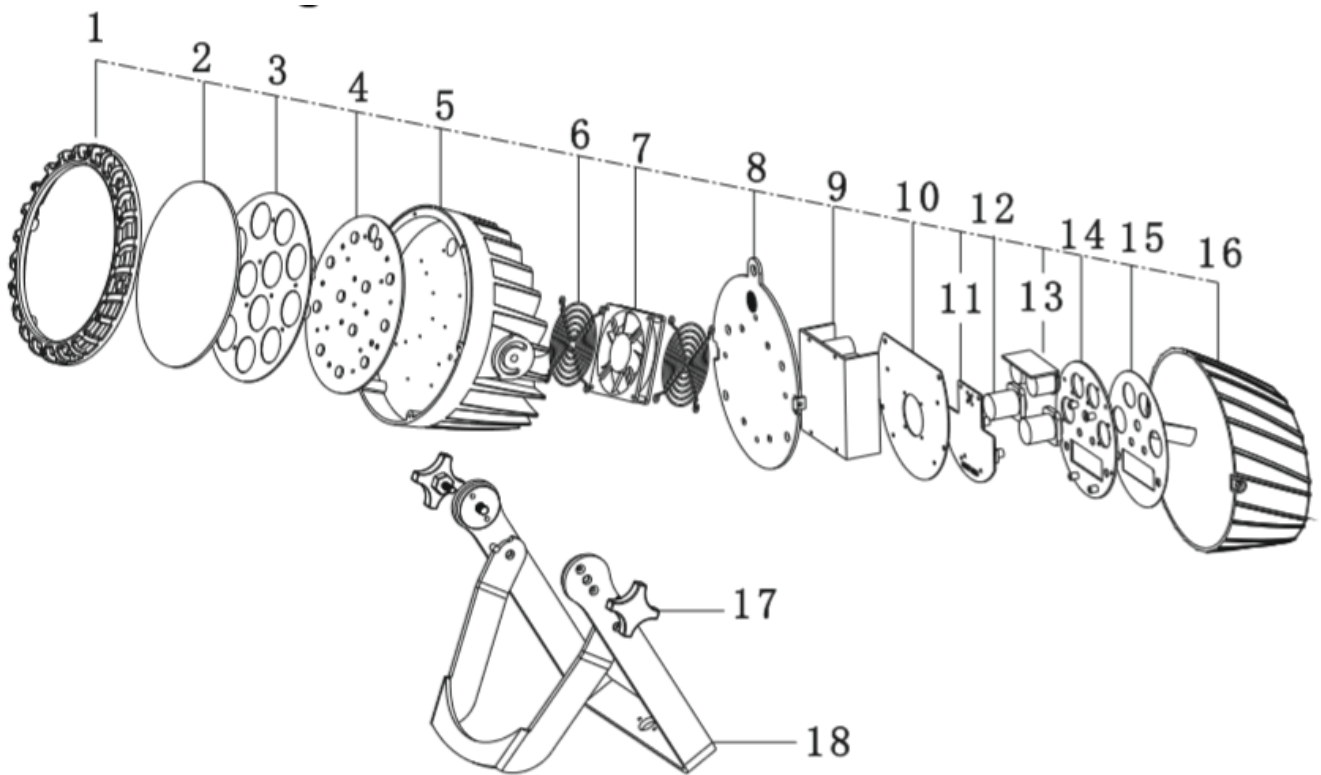

No.	Description	Part number CLF
1	CLF Front cover ring Hercules	CLF-12-295
2	CLF Tempered front glass Hercules	CLF-12-292
3	CLF Lens kit Hercules	CLF-12-286
4	CLF LED board Hercules	CLF-12-282
5	CLF Front case body Hercules	CLF-12-279
6	CLF Fan cover Hercules	CLF-06-106
7	CLF Fan Hercules	CLF-12-285
8	CLF Fan support plate Hercules	CLF-06-105
9	CLF Power supply Hercules	CLF-12-284
10	CLF Power supply support plate Hercules	CLF-06-104
11	CLF Display board Hercules	CLF-12-283
12	CLF Powercon input socket Hercules	CLF-03-007
13	CLF 3-pin DMX PCB Hercules	CLF-12-293
14	CLF Display support plate Hercules	CLF-12-289
15	CLF Backside sticker Hercules	CLF-12-280
16	CLF Back case body Hercules	CLF-12-278
17	CLF Knob bracket Hercules	CLF-06-116
18	CLF Outer bracket Hercules	CLF-12-290

Specifications

Physical

Length257 mm
Width206 mm
Height303 mm
Weight	5.5 kg without accessories

Dynamic Effects

color mixing	RGBWAP
color temperature control	CTO, variable 10 000 - 2500 K
LED Quantity:	12 PCS 6 in 1 LED
shutter effects	Electronic, with regular and random pulse, burst and strobe effects
Beam Angle:	25°

Control and Programming

ControlDMX
DMX channels	6/8/12/3/3
Setting and addressing	Control panel with backlit graphic display
Protocol	USITT DMX512-A

Construction

Color	Black
Housing	High strength die-casting aluminum
Protection rating.IP 20

Installation

OrientationAny
Minimum distance to combustible materials	100 mm. from fixture
Minimum distance to illuminated surfaces	200 mm. from fixture
LocationIndoor use only, must be fastened to structure or surface

Connections

AC power inputPowerCon input socket (blue)
AC power throughput.PowerCon output socket (grey)
DMX data in/out3/5-pin locking XLR

Electrical

AC power100-240 V nominal, 50/60 Hz
Maximum total power consumption105 W
Power supply unitAuto-ranging electronic switch mode
Power consumption, all effects static, zero light output	<10 W

Thermal

Cooling	Forced air (temperature-regulated, low noise, user-definable levels)
Maximum ambient temperature (Ta max.).	40° C
Minimum ambient temperature (Ta min.).	5° C